

Effects of continuous and intermittent forces on human fibroblasts *in vitro*

Aldo Carano, Giuseppe Siciliani

Department of Orthodontics, University of Ferrara, Ferrara, Italy

SUMMARY Orthodontics is based upon the cellular response to biomechanical forces. However, little is known about the way cells respond to such forces. An experimental model has been designed to study the morphological and metabolic behaviour of human cells, subjected to cyclical or static mechanical loads.

The model involves attaching human fibroblasts to silicone collagen-coated membranes, which are subjected to either continuous or cyclical stretching by a motor coupled with a movable supporting frame.

The effect of continuous or cyclical stretching on the secretion of collagenase, an enzyme thought to play an important role in the process of tooth movement, was measured. Cyclical stretching of fibroblasts over a 4-day period, approximately doubled collagenase production as compared with the control. Continuous stretching, on the other hand, was only 50 per cent as effective in enhancing enzyme release. In contrast, the secretion of the collagenase inhibitor was unaffected by either form of mechanical deformation.

To understand the effect of cyclical forces further, a morphological study using human fibroblasts was performed. It was found that stretching or compression delivered an immediate and proportional deformation of the cells. After 10–15 minutes the morphology of cells readapted to the new mechanical environment, causing a loss of the biological activation. This suggests that a new mechanical stimulus is necessary to induce a new biological reaction.

Introduction

The effect of mechanical forces on bone, cartilage, and connective tissue has been central to a number of studies in different branches of medicine. Although the human body is continuously stimulated by mechanical stresses, their regulatory effect on the biology of tissues is not well known and only recently has the effect of mechanical deformation on cell biology been investigated (Somjen *et al.*, 1979; Binderman *et al.*, 1984, 1988; Davidovitch *et al.*, 1984; Denitt *et al.*, 1984; Lansman *et al.*, 1987; Sachs, 1988; Sumpio *et al.*, 1988a,b; Sandy *et al.*, 1989).

Orthodontics and orthopaedics, besides sharing with other medical fields an interest in the biomechanical aspects of human physiology, are particularly relevant to this field because their therapeutic approaches are mainly based on the application of mechanical forces to teeth and the facial skeleton. All orthodontic appliances exert forces on tissues, inducing either a

stimulatory or an inhibitory effect on cellular activities, which form the basis of tissue remodelling.

The effects of mechanical forces on connective tissues have been investigated in experimental animals *in vivo* (Rodan *et al.*, 1975; Lanyon *et al.*, 1985; Rubin and Lanyon, 1985a,b) or in tissue culture *in vitro* (Carter *et al.*, 1987; Carter, 1987; Lanyon, 1987; Meikle *et al.*, 1989; Green *et al.*, 1990). Recently, it has been possible to study their effects on cell cultures although several problems have limited the progress in this area. The complex interrelationship between different tissues *in vivo* has limited the understanding of the separate biological roles of different tissues undergoing mechanical stresses. Studies performed on tissue cultures are complicated by the complex cellular interrelationships. Improvements in cell culture techniques could give a new impetus by helping to explain the intricate exchanges of biological information during mechanical deformation of

living tissues. In fact, it is now possible to observe the response of a single cell to different types of stresses and to focus on the most simple biological reactions of tooth movement.

In this paper a new experimental model, able to study the effect of mechanical forces on cell cultures, is described in detail. The purpose of this study was to assess whether human fibroblasts could respond directly to mechanical stimuli and to observe if there was any difference in the response to various types of mechanical deformation.

Materials and methods

Unless otherwise specified, reagents were from the Sigma Chemical Company, St Louis, MO, USA, and the media were from Gibco, Grand Island, NY, USA.

Cell cultures

Human fibroblasts were selected from the American Culture Collection, Rockville, MD, USA (CRL 1471 and 1467). The fibroblasts were cultured in Dulbecco's modified medium with 10 per cent foetal calf serum, 200 U/ml of penicillin, 200 µg/ml of streptomycin, and 30 mmol of Hepes as buffer (pH 7.6) at 37°C in humidified air with 5 per cent CO₂. Cell cultures from a common cell line were used for all the experiments. The cells were plated (3.5×10^5 cell/cm²) on to silicon membranes coated with rat tail collagen (type I). The elastic membrane was framed by two clamps connected to each other with a rigid but removable connector. Cells were cultured on a substratum that could be inserted into the mechanical device without distortion. After the framed membrane apparatus was attached to the mechanical device, the clamp connector was removed and the membrane deformed.

All the experiments were carried out 2–3 days following culture to allow the cells to reach confluence on the membrane and to limit the cellular proliferation.

Mechanical device (Fig. 1)

The mechanical device is composed of an electrical transformer (A), connected to a rotatory motor (B). The rotatory movement was transferred to a silicone membrane (D) through a mobile arm (C) and two fibreglass clamps attached to the membrane (E). The linear move-

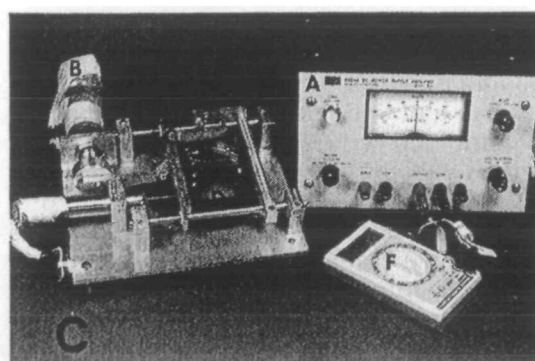
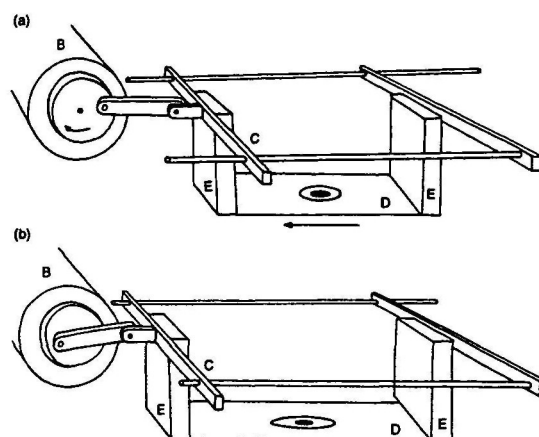

Figure 1 (a, b, c) The mechanical device is composed of an electrical transformer (A), connected to rotatory motor (B). The rotatory movement is transferred to a silicon membrane (D) through a mobile arm (C) and two episodic resin clamps attached to the membrane (E). The linear movements of the aluminum arm along two axes determined a proportionate elongation of the membrane, measured by a LVDT (Voltmeter) (F) as variation of electric potentials and transformed into millimetres with a mathematical constant.

ments of the aluminum arm along two axes determined a proportionate elongation of the membrane, measured by a LVDT (Voltmeter) (F) as variation of electric potential and transformed into millimeters with a mathematical constant. The rods and mount frame straddled an aperture in the base plate on which a standard-sized Petri dish (100 × 15 mm) was suspended. The membranes (D) were attached to the mount frame by two fibreglass clamps. The clamps served to suspend the sample in the culture medium, contained within the Petri dish, and transmit the desired displacement function to the membranes.

The clamps were designed so that only the sample and the fibreglass clamps were exposed to the culture medium. A separate aluminium loading clamp was available so that samples could be cultured away from the mechanism while being held in their own fibreglass clamps. Without disturbing the membrane, the loading clamp allowed the transfer of the membrane to the testing mechanism. The mechanical device was built and tested by the Department of Electrical Engineering, Massachusetts Institute of Technology, Boston, USA.

Mechanical forces on fibroblasts

The mechanical device utilized in this experiment was able to produce cyclical tensile forces on single cells. Human fibroblasts underwent a mechanical deformation equal to 7 per cent of their length with a cyclical rhythm total of 6 minutes (3 minutes stretched and 3 minutes relaxed). Other cells underwent a continuous stress equal to 7 per cent of their length. Finally, cells of the same culture which were not deformed, were used as controls. The morphological study was performed using transparent silicon membranes coated with collagen. Fibroblasts (10^3 cell/cm²) were plated on to membrane. The membrane was first rapidly elongated, applying a tensile force on the fibroblasts. After 10–15 minutes the same membrane was relaxed, creating a compressive force on the fibroblasts. The compression was directed only on one axis of the cells, the same axis along which the fibroblasts were previously elongated.

Enzyme measurements

Collagenase and collagenase inhibitor (TIMP) were measured with the immunological test (Welgus *et al.*, 1985). Each test measured the total quantity of each protein both in the free and molecular bound form. The enzyme measurements were expressed in percentages of the initial level of enzyme production for each single sample.

Protein synthesis

Protein synthesis of the cell culture was assessed using ³H-leucine incorporation. Cells were incubated in media supplemented with 1 μ Ci/ml of L-(4,5)-³H-leucine (New England Nuclear Inc., Jonesville, MA) for 6 hours. The cells were rinsed twice with PBS and fixed for 30 minutes

in 10 per cent trichloroacetic acid and 30 minutes in 5 per cent trichloroacetic acid. Lipid soluble materials were removed with ethanol/ether (3:1 v/v). The protein was then solubilized by digestion with 100 mM NaOH, for scintillation counting.

Statistics

All assays unless otherwise stated, were performed in triplicate. Statistical analysis was performed using a Student's *t*-test ($t > 4.3$ at 2 degrees of freedom). Significant differences were recorded when $P = 0.05$ or less. Where an error range is given, it represents the standard deviation.

Results

The fibroblasts, stimulated by a cyclical mechanical deformation (3 minutes stress, 3 minutes relaxation) of about 7 per cent of their length, produced 200 per cent more collagenase in comparison with the control (Fig. 2a). The production of collagenase inhibitor (TIMP) remained unchanged when compared to the control (Fig. 2b). During the experiments the practically unchanged level of total protein synthesis in relation to the control (Fig. 3) indicated that the effect of mechanical stimulus was specific to collagenase synthesis. When fibroblasts were deformed by a continuous distortion of the same amount as the cyclical one (7 per cent of their length), the increment of collagenase production was lower (30–60 per cent) in relation to the control (Fig. 4). These results emphasize the importance of the modality of mechanical force application to cell cultures and suggest that the same differential behaviour could influence tissue response to mechanical stimuli (Table 1).

Although it is reasonable to think that whenever a force is applied to a cell this could alter the cell morphology, there are no reports in the literature to substantiate this. The morphological study conducted in this experiment was designed to investigate this topic by observing what happened to the cell during and after application of the stimulus.

Figure 5A represents two fibroblasts in culture under light microscopy. In Fig. 5B the same cells are elongated approximately 10 per cent of their length. The elongation of the cells was measured by the increased distance of two dot-

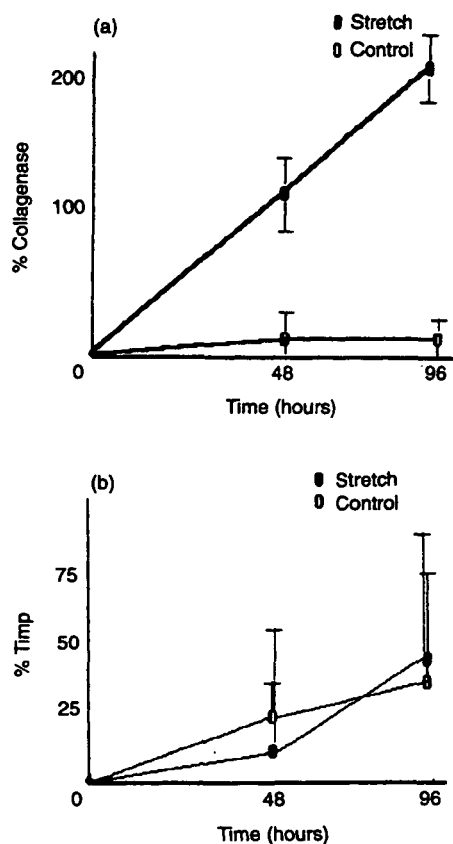

Figure 2 (a) Cyclic stretching of human fibroblasts over a 4-day period approximately doubles collagenase production as compared with the control (0). (b) The production of collagenase inhibitor (TIMP) is unchanged in the two different experimental conditions.

like irregularities of the substrate following the application of a tensile force. After ten to fifteen minutes of continuous distension, the fibroblasts changed their morphology even if the substrate was still under the same mechanical deformation (Figure 6). The reduction of previously elongated cell length was presumably dependent on cell migration. Even if the substrate was still elongated, the living cells readapted their morphology to the new physical environment and at that moment the mechanical stress was not effective on cell activity.

The same behaviour was noted in the cells after release of the membrane occurred. When the substrate was released the cells underwent a proportionate shortening of their length (Fig. 7A,B), but after 10–15 minutes the cells

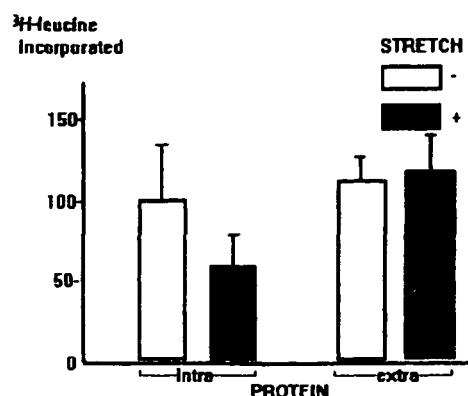

Figure 3 Intracellular total protein synthesis is reduced by 50 per cent in cells under mechanical deformation as compared with the control. The total protein quantity in the media is unchanged in the two different conditions of mechanical influence. These data indicate a generally unvarying anabolic capability in the two different treatments and, therefore, the collagenase increment of production could be considered very specific.

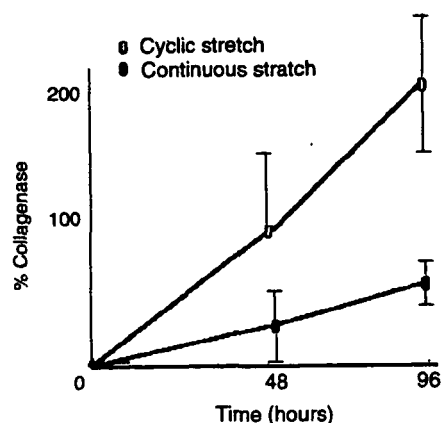

Figure 4 Cyclic stress (0) induces a 100–200 per cent increment of collagenase production in human fibroblasts. Continuous stretching, on the other hand, is only 50 per cent as effective in enhancing the enzyme release (0). This figure clearly shows that the rhythmic application of a force has a key role in inducing a biological response.

migrated on the membrane, losing the distortion imposed by the substrate (Fig. 7C).

Discussion

To date, the cause and effect relationship between the physical and biological components of biomechanics, has so far been studied with experimental models on animals (Rodan *et al.*, 1975; Shapiro *et al.*, 1979; Davidovitch *et al.*,

Table 1 The amounts of collagenase and TIMP productions of human fibroblasts are expressed in percentages of the initial level of enzyme production for each single sample in different experimental conditions

		Time (hours)	
		48	96
% Collagenase	Stretch	109.28 ± 42.8	212.14 ± 41.4
	Control	19.28 ± 24.9	18.37 ± 20.1
% TIMP	Stretch	11.90 ± 44.04	42.85 ± 41.66
	Control	21.42 ± 16.19	32.14 ± 36.9
% Collagenase	Cyclic	91.40 ± 44.82	196.90 ± 39.65
	Continuous	31.04 ± 20.68	60.34 ± 8.6

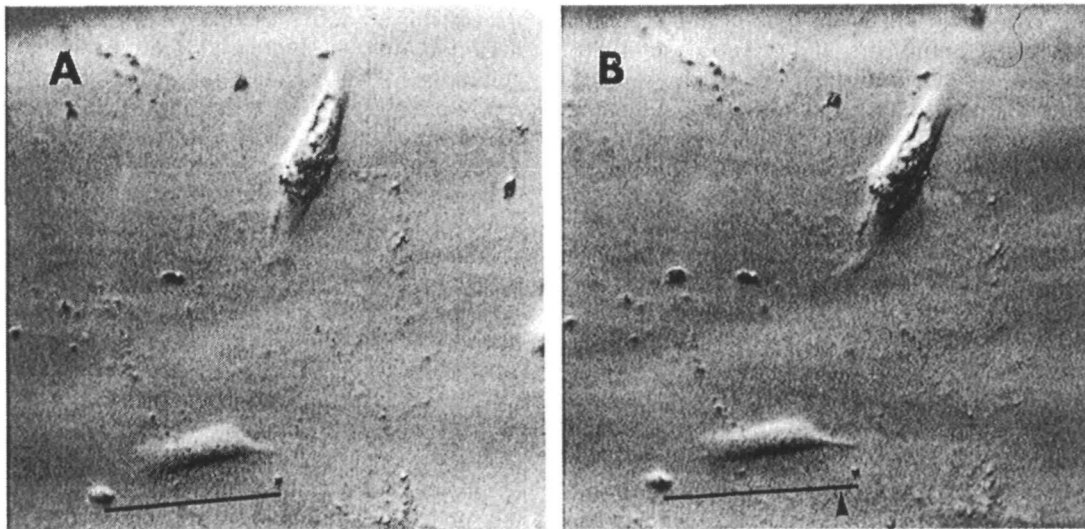

Figure 5 (A) Two human fibroblasts as they appeared at inversion light microscope for cell cultures (Nikon, Diaphot) attached on the collagen pretreated silicon membrane. Two irregularities of the substrate surface were chosen as reference points to measure substrate deformation. (B) The same two fibroblasts immediately after the membrane was elongated 10 per cent of its length. The arrow indicates the increment of distance between the two reference points. The elongation and the general change of cell morphology are dependent on the mechanical force applied to the substrate.

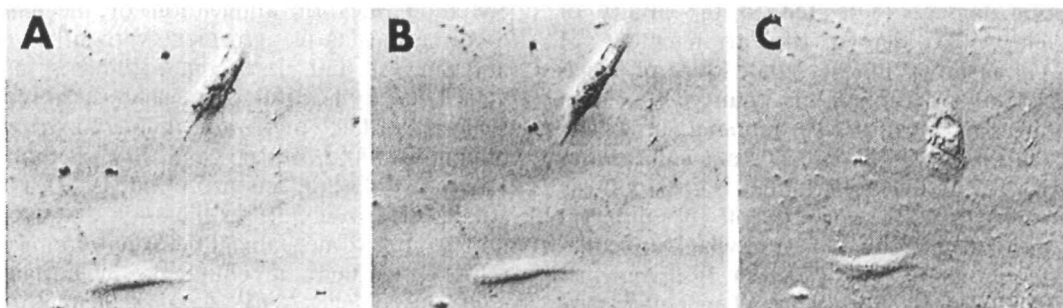

Figure 6 (A, B and C) Even if the membrane is still elongated 10 per cent of its length, after 10–15 minutes the cells change their morphology again. This time changes in cell shapes are dependent on migratory movement.

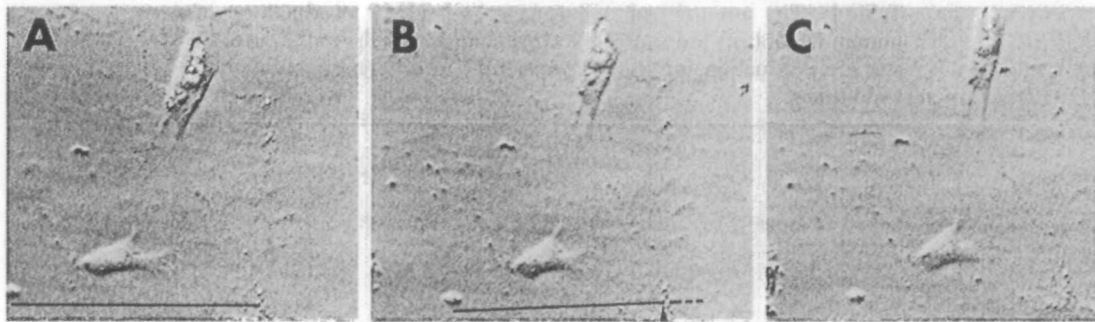

Figure 7 (A) The same two fibroblasts under inversion light microscopy after two hours of continuous stretching. (B) The human fibroblasts immediately after the membrane has been relaxed to its original dimensions. The reduction in length of the substrate induces compression of the cells. (C) Also in this case, after 10–15 minutes, the fibroblasts change their morphology losing the deformation imposed by the substrate.

1980; Lanyon *et al.*, 1985; Rubin and Lanyon, 1985a,b; Chumbley and Tuncay, 1986; Wenchen, 1990). Although these experiments can contribute to understanding the sequence of cellular events, the biological basis of tooth movement remains controversial. The role of different tissue components on the observed final effect is confusing. Human fibroblasts were the first cells examined with a new mechanical device, that was able to produce tensile forces on cell cultures. Fibroblasts are the principal constituents of connective tissues; they produce the fibrillar and macromolecular components of extracellular matrix at the sutures, the periodontal ligament, the periosteum, the articular ligaments and other connective tissues. The collagenous matrix represents a dynamic complex of organic components, the turnover of which is mainly dependent on the activity of collagenase and its inhibitor (TIMP). In the connective tissues mechanical stresses are supported by this extracellular organic matrix. The ability of tissues to sustain either physiological or parapsychological mechanical deformations without damage is related to the ability of fibroblasts to change the arrangement of the collagenous fibres. When the physical-mechanical environment is changed, the first step in connective tissue remodelling is the reorganization of the pre-existing collagenous matrix. The extracellular matrix is continuously remodelled by the production of different enzymes, the most important of which are collagenase and its inhibitor (TIMP). Both enzymes are produced by fibroblasts. The collagenase cleaves interstitial collagen type I, II, and III and the collagenase inhibitor (TIMP) binds

irreversibly to activate collagenase. In previous investigations an increased amount of collagenase has been detected in culture media from mechanically stressed coronal sutures as compared with the controls (Meikle *et al.*, 1980, 1989). Furthermore, it has been suggested that collagenase production and cell proliferation are correlated (Green *et al.*, 1990).

The mechanical device utilized in this experiment was able to produce cyclical and continuous tensile forces on isolated cultures of human fibroblasts. In both conditions, a statistically significant increase in collagenase production was observed, but when the cells are under cyclical deformation the increment of collagenase production is higher compared with the lower production when the cells are stimulated in a continuous fashion. The production of collagenase inhibitor (TIMP) remained unchanged when compared with the control, both with a continuous and a cyclical tensile force. This data on TIMP is in agreement with Green *et al.* (1990) and Meikle *et al.* (1989).

The differential cellular behaviour to different modalities of application of mechanical deformations is in agreement with other data and suggest that tissue remodelling is higher when the application of mechanical forces is cyclical rather than continuous in nature (Carano, 1990; Lottiurai *et al.*, 1983; Rubin and Lanyon, 1985 a,b; Shapiro *et al.*, 1979). Other studies on tissue cultures illustrate that cyclical application of mechanical deformation induced a higher synthesis of cellular products than the control (=cyclic AMP, Ca^{2+} , phospholipase, prostaglandines). Although these cellular products are indicated to be important keys in

cellular activation, previous studies have not illustrated which of the cell functions were stimulated during mechanical stress (Somjen *et al.*, 1979; Lottiurai *et al.*, 1983; Lanyon *et al.*, 1985; Lansman *et al.*, 1987; Sachs, 1988; Sumpio *et al.*, 1988a,b).

The purpose of this paper was to analyse cellular behaviour, rather than the biochemistry of cellular activation. When fibroblasts are deformed, the increase in collagenase synthesis is pivotal in destroying the previous fibrillar organization and in producing a new arrangement of the collagenous substrate, suitable for the new physical demand. The reason why fibroblasts are more stimulated with cyclical than continuous application of mechanical forces is fascinating, but at the same time very difficult to explain. This morphological study showed an immediate proportionate cellular deformation following the application of tensile or compressive forces. After 10–15 minutes, even if the substrate was still elongated, the fibroblasts changed their morphology. Although at present it is not clear what actually happens when cells are distorted, it is reasonable to suggest that the mechanism which activates them diminishes when the cells rearrange their morphology. From the photographic sequence (Figs 5–7) it can be concluded that the cells lose their sensitivity to the mechanical deformation applied to the substratum over a time range of 10–15 minutes. In order to reactivate the cells a new deformation of the substratum would be necessary. This observation could help to explain the reason why intermittent forces have a higher inductive capacity on tissues, compared with a continuous force of the same magnitude.

Conclusions

1. Cyclical forces are more effective than continuous forces in stimulating human fibroblast production of collagenase.
2. The differential cellular behaviour to differing modalities of application of mechanical deformations could be found in the quick cellular morphological readaptation to the new physical conditions of the substrate.

Address for correspondence

Dr Aldo Carano
Lungomare 15
74100 Taranto
Italy

Acknowledgements

The author wishes to thank Professor Alberta Zambonin-Zallone Department of Istology, University of Bari, Italy, and Professor Anna Teti for their guidance in the research. Particular thanks to Professor Richard Smith for his teaching in orthodontics and to Professor Steve Teitelbaum, Chairman, Department of Pathology, Jewish Hospital, Washington University Medical Center, for giving the author the possibility to conduct this research in his department.

References

- Binderman I, Shimshoni Z, Somjen D 1984 Biochemical pathways involved in the translation of physical stimulus into biological message. *Calcified Tissue International* 36: S82–S85
- Binderman I, Zor U, Kaye A M, Shimshoni Z, Harell A, Somjen D 1988 The transduction of mechanical force into biochemical events in bone cells may involve activation of Phospholipase A₂. *Calcified Tissue International* 42: 261–266
- Carano A 1990 Un nuovo approccio sperimentale allo studio delle forze meccaniche in ortodonzia. *Mondo Ortodontico* 1: 63–69
- Carter D R 1987 Mechanical loading history and skeletal biology. *Journal of Biomechanics* 20: 1095–1109
- Carter D R, Fyhire D P, Whalem R T 1987 Trabecular bone density and loading history: regulation of connective tissue biology by mechanical energy. *Journal of Biomechanics* 20: 785–794
- Chumbley A B, Tuncay O C 1986 The effect of indomethacin (an aspirin-like drug) on the rate of orthodontic tooth movement. *American Journal of Orthodontics* 89: 312–314
- Davidovitch Z 1982 Tissue reaction and bone turn-over in orthodontic treatment. In: Barrer H G (ed.) *Orthodontics state of art*. University of Pennsylvania Press, Philadelphia
- Davidovitch Z, Finkelson M D, Steigman S, Shanfeld J L, Montgomery P C, Korostoff E 1980 Electric current, bone remodeling and orthodontic tooth movement. II. Increase in rate of tooth movement and periodontal cyclic nucleotide level by combined force and electric current. *American Journal Orthodontics* 77: 33–47
- Davidovitch Z, Shanfeld J L, Montgomery P C, Lally E, Laster L, Furst L, Korostoff G 1984 Biochemical mediators of the effects of mechanical forces and electric cur-

- rent on mineralized tissues. *Calcified Tissue International* 36: S86-S97
- Denitt H T, Handley C J, Oakes B, Lowther D A 1984 *In vitro* response of condrocytes to mechanical loading. The effect of short term mechanical tension. *Connective Tissue Research* 12: 97-109
- Green D D, Hembry R M, Atkinson S J, Reynolds J J, Meikle M C 1990 Immunolocalization of collagenase and tissue inhibitor of metalloproteinases (TIMP) in mechanically deformed fibrous joints. *American Journal Orthodontics and Dentofacial Orthopedics* 97: 281-288
- Lansman J, Hallam T J, Rink T J 1987 Single stretch-activated ion channels in vascular endothelial cells as mechanotransducers? *Nature* 325: 811-813
- Lanyon L E 1987 Functional strain in bone tissue as an objective and controlling stimulus for adaptive remodeling in bone. *Journal of Orthopaedic Research* 20: 1083-1093
- Lanyon L E, Rubin C T, Baust G 1985 Modulation of bone loss during calcium insufficiency by controlled dynamic loading. *Calcified Tissue International* 37: 411-417
- Lottiurai V S, Kolbros P, Glagov S, Zarius C K, Matheus M B 1983 Morphologic alteration of cultured arterial smooth muscle cells by cyclic stretching. *Journal of Surgical Research* 35: 490-497
- Meikle M C, Sellers A, Reynolds J J 1980 Effect of tensile mechanical stress on the synthesis of metalloproteinases by rabbit coronal sutures *in vitro*. *Calcified Tissue International* 30: 77-82
- Meikle M C, Heath J K, Atkinson S J, Hembry S J, Reynolds J J 1989 Molecular biology of stressed connective tissues at sutures and hard tissues *in vitro* In: Norton L A, Burstone C J (eds) *The biology of tooth movement*. CRC Press, Boca Raton, pp. 71-86
- Rodan C A, Bourret L A, Harvey A, Mensi T 1975 Cyclic AMP and cyclic GMP: mediators of the mechanical effects on bone remodeling. *Science* 189: 467-469
- Rubin C T, Lanyon L E 1985 Regulation of bone mass by mechanical strain magnitude. *Calcified Tissue International* 37: 411-417
- Rubin C T, Lanyon L E 1985b Regulation of bone formation by applied dynamic loads. *Journal of Bone and Joint Surgery* 66A: 397-402
- Sachs F 1988 Mechanical transduction in biological systems. *Critical Reviews in Biomedical Engineering* 16: 141-169
- Sandy J R, Meghij S, Scutt A M, Harwey W, Harris M, Meikle M 1989 Murine osteoblasts release bone-resorbing factors of high and low molecular weights: stimulation by mechanical deformation. *Bone and Mineral* 5: 155-168
- Shapiro E, Roeber F W, Klempeur L S 1979 Orthodontic movement using pulsating force induced piezo-electricity. *American Journal of Orthodontics* 76: 59-66
- Somjen D, Binderman I, Berger E, Harell A 1979 Bone remodelling induced by physical stress in prostaglandin E₂ mediated. *Biochemical and Biophysical Acta* 627: 91-100
- Sumpio B E, Banas A J, Johnson G 1988a Response of porcine aortic smooth muscle cells to cyclic tensional deformation in culture. *Journal of Surgical Research* 44: 696-701
- Sumpio B E, Banas A J, Link W G, Johnson G 1988b Enhanced collagene production by smooth muscle cells during repetitive mechanical stretching. *Archivia Surgery* 123: 1233-1236
- Welgus H E, Jeffrey J J, Eisen A Z, Roswit W T, Stricklin G P 1985 Human skin fibroblasts collagenase: interaction with substrate and inhibitor. *Collagen Related Research* 5: 167-179
- Wenchen L 1990 Experimental study of the effect of prostaglandin administration on tooth movement with particular emphasis on the relationship to the method of PGE₁ administration. *American Journal of Orthodontics and Dentofacial Orthopedics* 98: 231-241